

Vertical Hanging Obstacles

Recommended Tools:

- 5/32" (4.0 mm) Hex Key for 1.25" (1.66" OD) Pipe
- 3/16" (4.8 mm) Hex Key for 1.5" (1.90" OD) Pipe

Step 1:

Slide your ninja obstacle onto the vertical hanging pipe so that it is mounted above the welded Bottom.

Step 2:

Rotate each bearing so that the Set Screws are facing the same position. This will ensure the obstacle is balanced correctly on the pipe.

Step 3:

Using the correct size Hex Key, tighten the set screws until they are firmly secured. Then hang the pipe with mounted obstacle on your rig.

Ninja Obstacle (Side View)

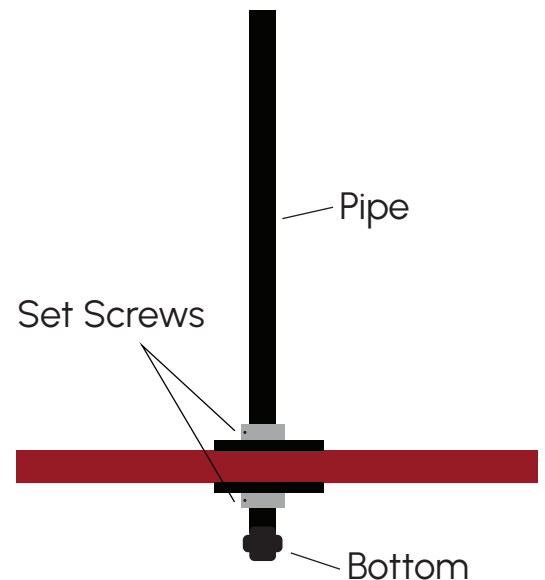

Need help?

Call 1-800-932-3339 or
Email info@gymsupply.com